

CHALLENGER

**CAST DUCTILE IRON
OUTSIDE SCREW GATE VALVE
RESILIENT SEATED
16 BAR RATED**

MODEL FM 601

FEATURES

- SIZE RANGE:
- 65MM - 300MM
- 16 BAR RATED
- ISO 5752 Series 3 FACE TO FACE
- ANTI CLOCKWISE OPEN
- FBE COATED BLUE
- FOOD GRADE LINER AS4020 TESTED
- LUGGED DESIGN AS2129 TABLE E

FM APPROVED

RESILIENT SEAT
BUBBLE TIGHT SHUT OFF
1600 kPa @ 40°C
AS2129 TABLE E

SUITABLE FOR:
WATER, SEWAGE
AND NEUTRAL LIQUIDS

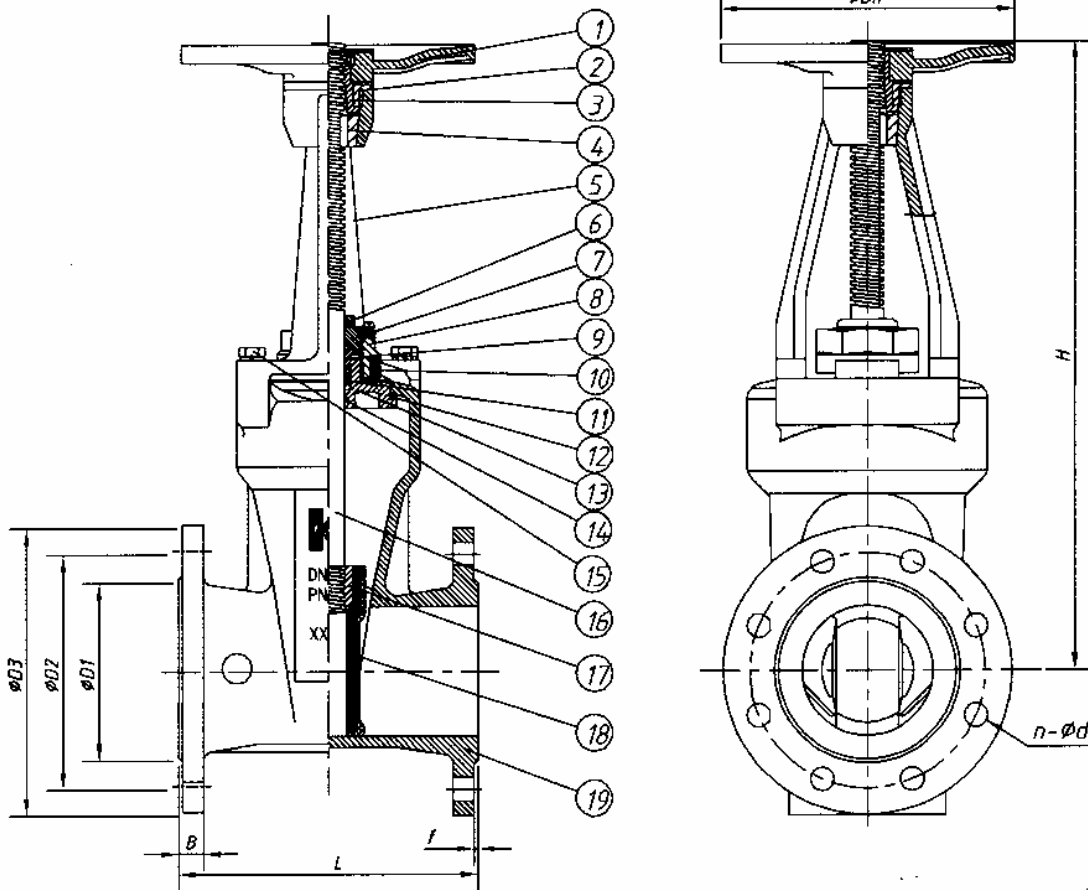
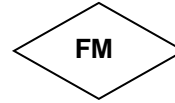

COMPONENTS and MATERIALS

1	HANDWHEEL	DUCTILE IRON	6	WIPER RING	NBR RUBBER	11	GLAND PACKING	NBR RUBBER	16	STEM	SS 420
2	RETAINER	BRONZE	7	LOCK COVER	BRASS	12	BONNET GASKET	NBR RUBBER	17	WEDGE NUT	GUNMETAL
3	YOKE NUT	BRONZE	8	LOCK NUT	DUCTILE IRON	13	BONNET	DUCTILE IRON	18	WEDGE	DUCTILE IRON CORE
4	STOP BLOCK	BRASS	9	GLAND	BRASS	14	'O' RING	NBR RUBBER	19	BODY	DUCTILE IRON
5	YOKE	DUCTILE IRON	10	Y SUPPORT	DUCTILE IRON	15	YOKE BOLT	ZINC COATED STEEL 8.8			