



AMCV

A globe showing the continents of North America, South America, and Australia. A white rectangular box with a black border is superimposed over the globe, containing the text "DELATITE™ VALVES" in red.

DELATITE™ VALVES

Eccentric Plug Control Valve Severe Service Applications

“Delatite solve your valve problems”

The Latest Technology in Severe Service Eccentric Plug Valves
Erosion and Corrosion Control



Model **AMCV**

Metal Seated Eccentric Plug Valves for:

- High Demanding Applications
- Mining Industry
- Corrosion Protection
- Erosion Protection

Typical Applications:

- Slurry Control
- Control of Erosive fluids
- Control of Corrosive fluids
- Control of Normal services

Typical Industries:

- Mining
- Oil & Gas
- Petrochemical
- Pulp & Paper

AMCV

Introduction:

Eccentric plug control valves have become one of the valves of choice for control valve users. This style of valve offers an ability to handle solids and slurries. The design of the valve offers larger capacity (higher Cv's) than globe style valves. Rangeability is approximately 150:1 compared to 50:1 for a globe valve, and 20:1 for butterfly valves.

The design of the valve is robust, light weight, and it is an economical alternative for your control valve applications.

The Delatite AMCV is fitted with a low hysteresis, high thrust, pneumatic piston actuator, with a patented coupling between the actuator and valve stem which eliminates backlash.

With the importance of safety, the Delatite AMCV can be supplied complete with spring return actuator (fail open, fail closed, or fail in place), or double acting.

As the valve has a straddle shaft flow capacity can be up to 70% higher than other rotary plug valves.

The shaft is supported by 2 large bearings.

The Delatite AMCV is manufactured in sizes 50/25 thru to 300mm, and are available in either in flanged or wafer style.

Flanges: RF ANSI 150#, 300#, and 600#.

Wafer: ANSI 150#, 300#, and 600#.

All these advantages make the Delatite AMCV an excellent solution for your process control applications.

AMCV Seating & Closing:

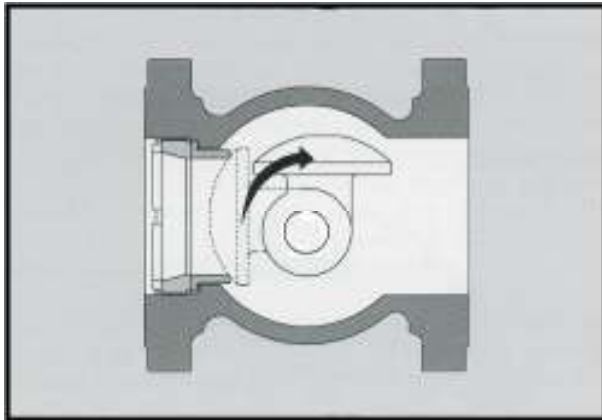

Valve Opening

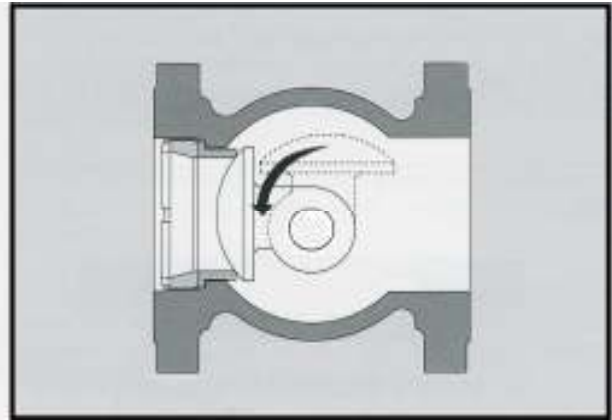

Valve Closing

As the valve opens, the plug lifts off the seat, and then rotates smoothly out of the flow stream. The chance of pipe shock and water hammer is greatly reduced.

As the valve closes in the last degrees of travel, the plug pushes onto the seat to perform the seal.

The design of the Delatite AMCV gives a zero breakout torque, which allows smaller actuators to be used.

The trim has been design with a straddle shaft and due to the fact the plug rotates out of the flow path, the Delatite AMCV obtains a higher Cv (flow coefficient) than other manufacturers rotary valves.

With the high Cv values, and the use of smaller actuators, the Delatite AMCV is a very cost competitive valve for your process control applications.



The Latest Technology In Eccentric Plug Valves.

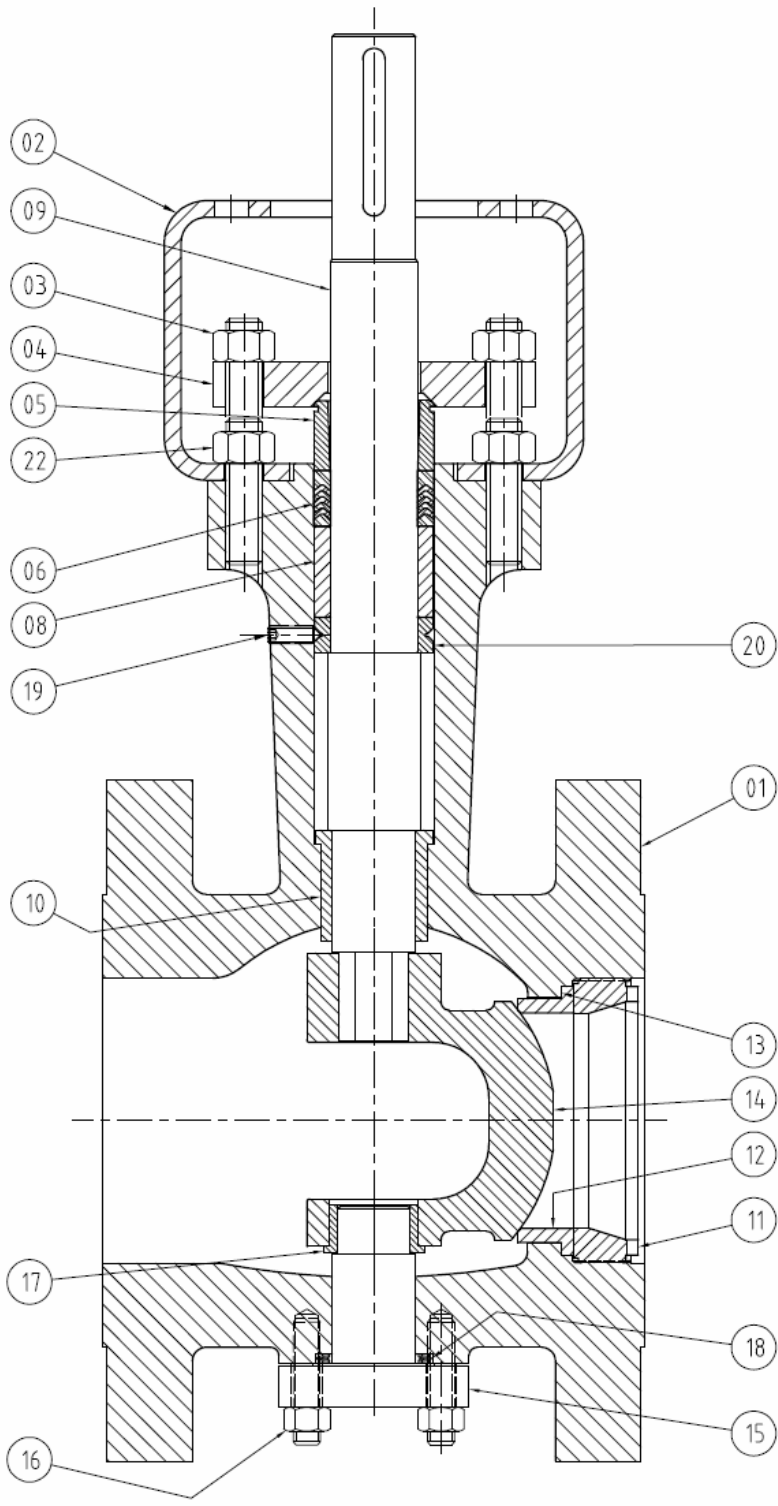

ITEM No.	DESCRIPTION
01	#600 LB WAFER VALVE BODY
	#150 LB FLG'D VALVE BODY
	#300 LB FLG'D VALVE BODY
	#600 LB FLG'D VALVE BODY
02	YOKE
03	YOKE STUD AND NUT KIT
04	GLAND FLANGE
05	PACKING FOLLOWER
06	PACKING KIT
08	PACKING SPACER
09	SHAFT
10	SHAFT BEARING
11	SEAT RETAINER
12	SEAT
13	SHIM SET
14	PLUG
15	POST
16	POST STUD AND NUT KIT
17	POST BEARING
18	POST GASKET
19	RETENTION BRG' SET SCREWS
20	SHAFT RETENTION BEARING
22	BONNET STUD AND NUT KIT
23	FLOW IDENTIFICATION PLATE
24	VALVE I.D. PLATE

AMCV

Bills of Material:

Description	Material
Body*	Stainless Steel ASTM A 351 CF8M
Plug	17-4-PH 316 SS coated Alloy 6 316 SS coated Tungsten
Seat	Stainless Steel CF8M 316 SS coated Alloy 6 316 SS coated Tungsten
Shaft	17-4-PH
Post	17-4-PH
Bearings	Duplex 2205
Packing Spacer	316 SS
Anti Extrusion Ring	316 SS
Seat Retainer	Stainless Steel CF8M 316 SS coated Alloy 6 316 SS coated Tungsten
Packing	PTFE V Rings Grafoil

Description	Material
Body*	ASTM A 216 WCB
Plug	17-4-PH 316 SS coated Alloy 6 316 SS coated Tungsten
Seat	Stainless Steel CF8M 316 SS coated Alloy 6 316 SS coated Tungsten
Shaft	17-4-PH
Post	17-4-PH
Bearings	AISI 440C
Packing Spacer	316 SS
Anti Extrusion Ring	316 SS
Seat Retainer	Stainless Steel CF8M 316 SS coated Alloy 6 316 SS coated Tungsten
Packing	PTFE V Rings Grafoil

* Any other cast materials that can meet the temperature / pressure class.



AMCV

Options for Slurry Applications:

Coatings available

Delatite Valves have access to the latest in coating technology.

This coating can be applied to the

- Body
- Plug
- Seat
- Seat Retainer

With over 60 years experience the Delatite coating suppliers offer

- HVOF
- Low velocity oxygen fuel
- Twin wire arc jet
- Plasma flame
- Plasma transferred arc

Coatings available up to 800 combinations including

- Ceramic
- Alloy #6
- Tungsten carbide
- Chrome carbide

Delatite Valves have evaluated hundreds of metallic, carbide, and ceramic coatings to give the customer the best coating solution for their applications.

We offer the most technically advanced coatings to protect valves in

- Pressure acid leaching
- Pressure oxidation systems
- Any other erosive and corrosive applications



AMCV

Delatite Carbide Selection:

Carbide for Wear Protection

Surface Coating	Description
LLK-1515	Hard dense coating with good abrasion, erosion resistance: Low oxidation and corrosion resistance. Max operating temp 500 DegC.
LLK-1516	Hard dense coating with good abrasion, erosion resistance: Low oxidation and corrosion resistance. Good bond strength. Max operating temp 500 DegC.
LLK-1518	Hard dense coating with good abrasion, erosion resistance: Low oxidation and corrosion resistance. Smooth coatings; High bond strength. Fine micro structure. Max operating temp 500 DegC.
LLK-1529	Hard dense coating with good abrasion, erosion resistance: Used for Petrochemical and Off shore Oil & Gas industries. Max operating temp 500 DegC.
LLK-1551	Hard dense coating with good abrasion, erosion resistance: High oxidation and corrosion resistance. Smooth coatings; High bond strength. Max operating temp 750 DegC.
LLK-1554	Hard Chrome replacement. High corrosion and abrasion resistance. Usable in water based solution and wet corrosive environments. Smooth coatings; High bond strength. Max operating temp 500 DegC.

Surface Coating	Description
LLK-1558	Hard Chrome replacement. High corrosion and abrasion resistance. Usable in water based solution and wet corrosive environments. Smooth coatings; High bond strength. Max operating temp 500 DegC.
LLK-1582	Coarse Carbide. Excellent for severe abrasion and wear resistances. Good solid particle erosion resistance. Recommended for cavitation and wear. Protection at high temperatures. Smooth: as sprayed surfaces. Max operating temp 870 DegC.
LLK-1583	Coarse Dense Carbide. Excellent for severe abrasion and wear resistances. Good solid particle erosion resistance. Recommended for cavitation and sliding wear protection at high temperatures. Max operating temp 870 DegC.
LLK-1704	Hard, Corrosion and wear resistances. Ceramic coating. Insoluble in acidic / alkalis. Max operating temp 540 DegC.
LLK-1712	Lower hardness but higher toughness. Used in wear applications where increased hardness is required. Max operating temp 540 DegC.
LLK-1516	Hard dense wear resistant coating. Good corrosion resistance. Higher mechanical shock resistance.



The above mentioned coatings are just a small example of the coatings that are available to meet the customer severe service needs for erosion, corrosion, abrasion, impact resistance, and to maintain reliable control of your manufacturing process.

Delatite Valves Pty Ltd can supply valves with a combination of 100's of coatings giving the customer protection against:

- Abrasion
- Corrosion
- Erosion
- High Temperature
- Wear Protection

All coatings are applied using the latest state of the art application methods.

“Delatite solve your valve problems”

Delatite Valves are dedicated to providing High Quality Products of Superior Design which are all supported by excellent customer service.

Delatite are Committed to solving Severe Service Valve problems in today's industries.

Total Quality Management is our Commitment to our Customers.

We go out of our way to understand the Customers needs and to provide solutions which meet or exceed our customers' needs.

This commitment is carried across all departments of the company. Including

- Sales
- Engineering
- Product Development

This Commits Delatite to ongoing quality and performance improvements to meet our customers needs.

We aim to meet our Customers Needs First Time and on Time.

Valves have been designed to meet the ANSI Standards for Valves.

Valves are Tested to conform with ANSI B16.104 and ANSI B16.34

All machining, hard coating, assembly, and repair facilities are accredited to ISO 9001 : 2000

Repair facilities are ISO 9001 : 2000

Certificate No QEC 2420

Pressure test equipment traceable to NATA.



AMCV Cv Tables:

Valve size mm	Valve size inches	Cv at 90 degrees rotation	
		Shaft Upstream	Shaft Down Stream
50/25	2 /1.0	21	18
50/40	2 /1.5	50	47
50	2	78	80
80	3	220	242
100	4	356	408
150	6	790	935
200	8	1120	1660
250	10	1745	2465
300	12	2520	3350

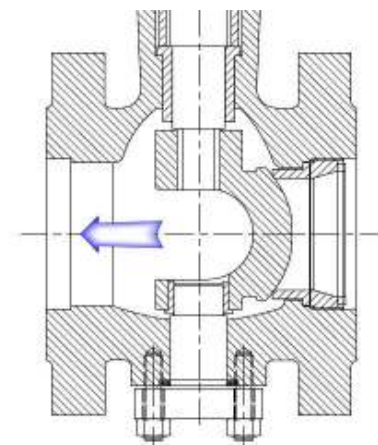

Shaft Downstream

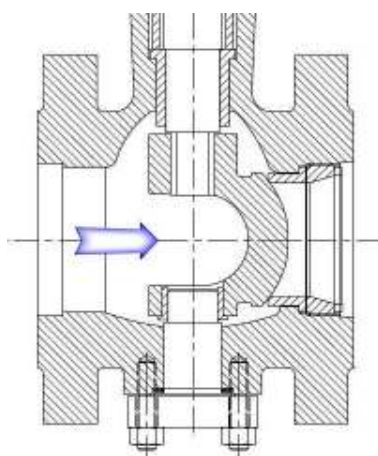

Shaft Upstream

Valve size mm	Valve size inches	Maximum allowable Differential Pressure	
		kPa	PSI
50/25 - 150	2 /1.0 - 6	10,000	1450
200	8	7,600	1100
250	10	3,100	450
300	12	2,200	320

Valve size mm	Valve size inches	Actuator per Size Selection table for actuators 5.5 Bar	
50/25	2/1.0	A23-SX	A13-DA
50/40	2/1.5	A23-SX	A13-DA
50	2	A23-SX	A21-DA
80	3	A24-SX	A22-DA
100	4	A33-SX	A23-DA
150	6	A34-SX	A31-DA
200	8	A43-SX	A34-DA
300	12	A44-SX	A42-DA



AMCV

Pressure – Temperature Rating:

Material : A351-CF8M

Temperature		Standard Pressure Class					
		150#		300#		600#	
Deg C	Deg F	kPa	PSI	kPa	PSI	kPa	PSI
	-20 to 100	1999	290	5170	750	10339	1500
93	200	1792	260	4687	680	9409	1365
149	300	1620	235	4205	610	8409	1220
204	400	1516	220	3929	570	7858	1140
260	500	1413	205	3653	530	7341	1065
316	600	1344	195	3481	505	6962	1010
371	700	1275	185	3343	485	6686	970
427	800	1241	180	3205	465	6376	925
482	900	1172	170	3033	440	6066	880
538	1000	1103	160	2895	420	5790	840
593	1100	1068	155	2792	405	5549	805
649	1200	689	100	1792	260	3550	515
704	1300	448	65	1172	170	2378	345
760	1400	241	35	655	95	1310	190
816	1500	138	20	345	50	724	105

Material : A216-WCB

Temperature		Standard Pressure Class					
		150#		300#		600#	
Deg C	Deg F	kPa	PSI	kPa	PSI	kPa	PSI
	-20 to 100	1964	285	5101	740	10201	1480
93	200	1792	260	4653	675	9305	1350
149	300	1585	230	4515	655	9064	1315
204	400	1379	200	4377	635	8754	1270
260	500	1172	170	4136	600	8271	1200
316	600	965	140	3791	550	7548	1095
371	700	758	110	3688	535	7341	1065
427	800	551	80	2826	410	5687	825
482	900	345	50	1172	170	2378	345
538	1000	138	20	345	50	724	105

Material Pressure & Temperature rating per
ASME / ANSI B16-34-1988
Standard Class Ratings

Note: A216-WCB is not recommended for prolonged use above 427 Deg C or 800 Deg F

AMCV

Dimensional Data:

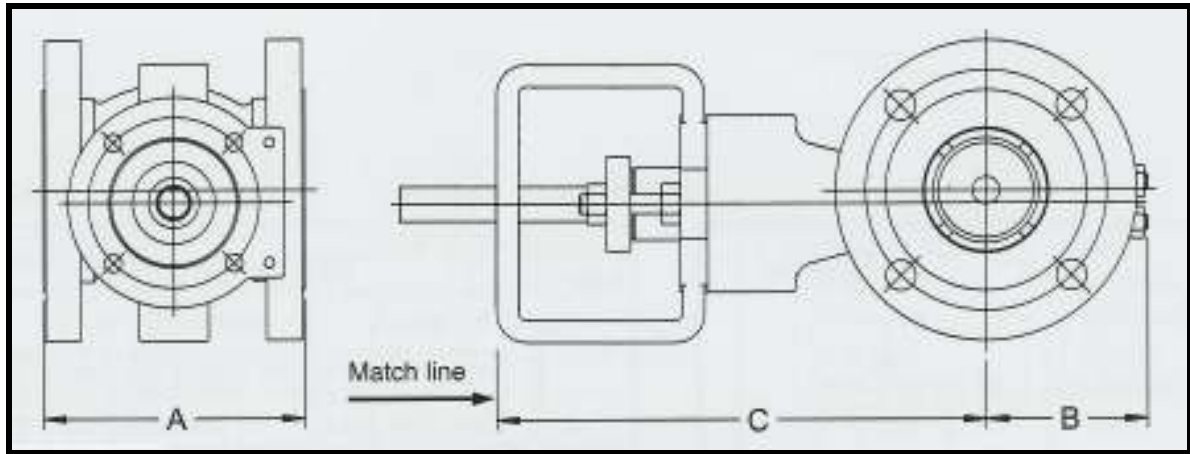

Valve Size		Stem Diameter		A		B		C	
mm	inch	mm	inch	mm	inch	mm	inch	mm	inch
50/25	2 / 1.0	20	0.75	124	4.9	86	3.4	TBA	TBA
50/40	2 / 1.5	20	0.75	124	4.9	86	3.4	TBA	TBA
50	2	20	0.75	124	4.9	86	3.4	TBA	TBA
80	3	25	1.0	165	6.5	119	4.7	TBA	TBA
100	4	30	1.25	194	7.6	127	5	TBA	TBA
150	6	40	1.5	229	9	160	6.3	TBA	TBA
200	8	40	1.5	243	9.6	190	7.5	TBA	TBA
250	10	40	1.5	273	10.7	226	8.9	TBA	TBA
300	12	40	1.5	292	11.5	267	10.5	TBA	TBA

AMCV

Valve Model – Coding Number:

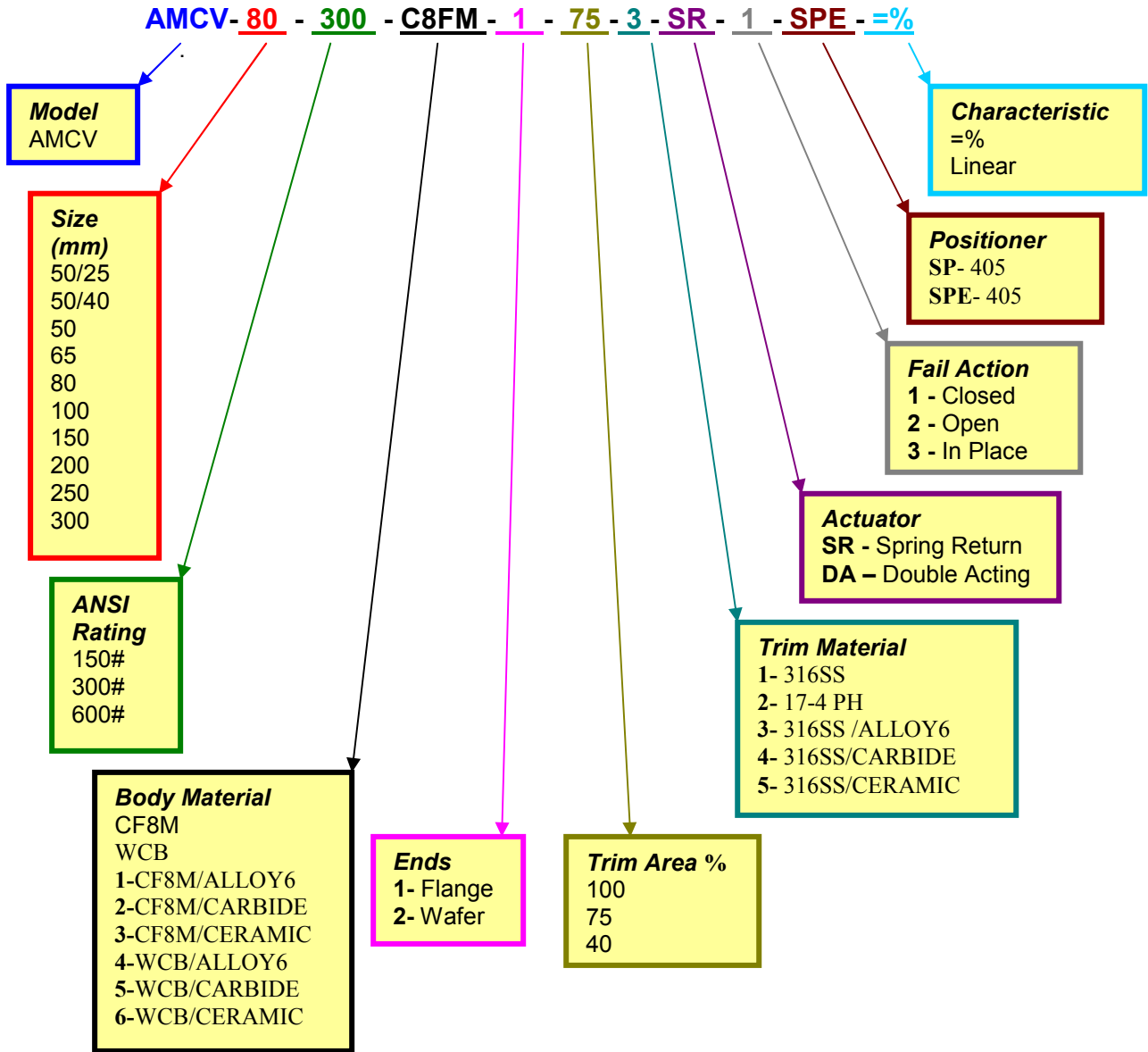



The information and specification in this publication are presented for information purposes only. While every effort has been made to ensure accuracy they should not be considered as certified information. Delatite are continually improving the performance of their range of valves. Information in this brochure is subject to change without notice.

For further information or verification please contact your Delatite Valve Representative

Manufactured in Australia by:
Delatite Valves Pty Ltd
Victoria
Australia
sales@delatitevalves.com
www.delatitevalves.com

Authorised Distributor





DELATITETM VALVES